



ND-6021/ND-6024
Analog Input Modules
User's Guide

Manual Rev.: 4.1
Revision Date: June 27, 2022
Part Number: 50M-00082-1000

LEADING EDGE COMPUTING



Preface

Copyright

Copyright © 1996-2022 ADLINK Technology, Inc. This document contains proprietary information protected by copyright. All rights are reserved. No part of this manual may be reproduced by any mechanical, electronic, or other means in any form without prior written permission of the manufacturer.

Disclaimer

The information in this document is subject to change without prior notice in order to improve reliability, design, and function and does not represent a commitment on the part of the manufacturer. In no event will the manufacturer be liable for direct, indirect, special, incidental, or consequential damages arising out of the use or inability to use the product or documentation, even if advised of the possibility of such damages.

Trademarks

NuDAM is registered trademarks of ADLINK Technology Inc.

Product names mentioned herein are used for identification purposes only and may be trademarks and/or registered trademarks of their respective companies.

Revision History

Revision	Description	Date
4.0	Previous release	2001-06-05
4.1	Updated ND-6024 Pin Assignments	2022-06-27

Table of Contents

Preface	ii
Chapter 1 Introduction	1
1.1 About the NuDAM Analog Output Modules.....	1
1.2 Overview of NuDAM-6021.....	2
1.3 Overview of NuDAM-6024.....	7
Chapter 2 Initialization & Installation	13
2.1 Software Installation	13
2.2 Initializing a Brand-New Module.....	14
2.3 Install a New NuDAM to a Existing Network	16
2.4 Application Wiring for NuDAM-6021.....	17
2.5 Application Wiring for NuDAM-6024.....	18
Chapter 3 Command Set	19
3.1 Command and Response.....	19
3.2 Summary of Command Set.....	22
3.3 Set Configuration.....	24
3.4 Read Configuration	28
3.5 Read Module Name	29
3.6 Read Firmware Version.....	30
3.7 Reset Status	31
3.8 Synchronized Sampling (6024 only)	32
3.9 Read Synchronized Data (6024 only)	33
3.10 Digital Input (6024 only)	34
3.11 Analog Data Output.....	35
3.12 4mA Offset Calibration	37
3.13 20mA Calibration.....	38
3.14 Trim Calibration.....	39
3.15 Save Power On Analog Output Value.....	40
3.16 Last Value Readback	41
3.17 Current Readback	42
3.18 Read.....	43
3.19 Change Leading Code Setting.....	45
3.20 Set Host Watchdog Timer & Safety Value	47
3.21 Read Host Watchdog Timer & Safety Value	50
3.22 Host is OK	52

Chapter 4 Data Format	53
4.1 Unit Conversion	53
4.2 Engineering Units	54
4.3 Percent of FSR.....	55
4.4 Hexdecimal Format	56
4.5 Summary of Data Format	57
Chapter 5 Analog Output Calibration.....	59
5.1 Calibration	59
5.2 Analog Output Module Calibration	59
Safety Instructions.....	61
Getting Service	62

1

Introduction

1.1 About the NuDAM Analog Output Modules

The NuDAM provides an analog output module which can convert the digital command to analog. The basic features of each module are shown here.

- NuDAM-6021: analog signal output module with safety functions
- NuDAM-6024: 4 channel analog output module

1.2 Overview of NuDAM-6021

What is NuDAM-6021?

ND-6021 is an analog signal output module. It receives the digital command from host computer through RS-485 network. The format of the digital value can be engineering units, hexadecimal format or percentage of full-scale range(FSR). A microprocessor is used to convert the digital command to digital value to send to DAC. The DAC converts the digital value into analog form. The analog output can be either voltage or current output.

The ND-6021 is designed for safety. It provides many safety functions such as isolation, watchdog, and power on safe value. The opto-isolators provide 5000Vrms isolation voltage to isolate the digital section and the remote-controlled analog equipment. The damage of power surges is avoided.

Another safety function is the watchdog. Whenever the host is loss contact with the remoted NuDAM module, or the micro-processor is down, the module will reset itself and send the safety value to the analog output therefore the industry safety is guarantee. The safety value / power-up value can be set by configuration software.

The analog output can be readback through the module's ADC. which can monitor the 'real' output of the device. The host can check the digital command and the real output to avoid short circuits. The slew rate of the output signal is also controllable by software.

Features of NuDAM-6021

- One uni-polar analog output channel
- Two sets of differential current and voltage output terminals
- Versatile digital signal format
- Programmable host watchdog timer for host failure protection
- Internal watchdog timer for device failure protection
- Easy programming by software
- Easy installation and wiring

Specifications of NuDAM-6021

◆ **Interface**

- Interface: RS-485, 2 wires
- Speed (bps): 1200, 2400, 4800, 9600, 19.2K, 38.4K

◆ **Analog Output**

- Signal Output type: Differential type
- Resolution: 12 bits
- Accuracy: $\pm 0.1\%$ of FSR for current output
 $\pm 0.2\%$ of FSR for voltage output
- Unit Conversion: V or mA
- Output range: Voltage output: 0 to 10 V (uni-polar)
Current output: 0 to 20 mA, 4 to 20 mA
- Maximum Sampling Rate: 100 samples /sec
- Slew rate: Voltage output: 0.0625 to 64 V/sec Current
output: 0.125 to 128 mA/sec
- Internal Current Load Resistor: 500 Ω (%1)

◆ **Readback Analog Input**

- Accuracy: $\pm 0.2\%$ of FSR

◆ **Isolation**

- Isolation voltage: 5000 Vrms

◆ **Watchdog Function**

- Module internal watchdog timer: 150 ms
- Power failure threshold: 4.65 V
- Host programmable watchdog: 100 ms ~ 25.500 sec

◆ **Power**

- Power supply : +10V to +30V
- Power consumption: 1.0W

Pin Definitions of ND-6021

Pin #	Signal Name	Description
1	+IOUT	Positive Current Output Terminal
2	-IOUT	Negative Current Output Terminal
3	+VOUT	Positive Voltage Output Terminal
4	-VOUT	Negative Voltage Output Terminal
6	Default*	Initial state setting
7	(Y) DATA+	RS-485 series signal, positive
8	(G) DATA-	RS-485 series signal, negative
9	(R) +Vs	Power supply, +10V~+30V
10	(B) GND	Ground

A Look at ND-6021 & Pin Assignment

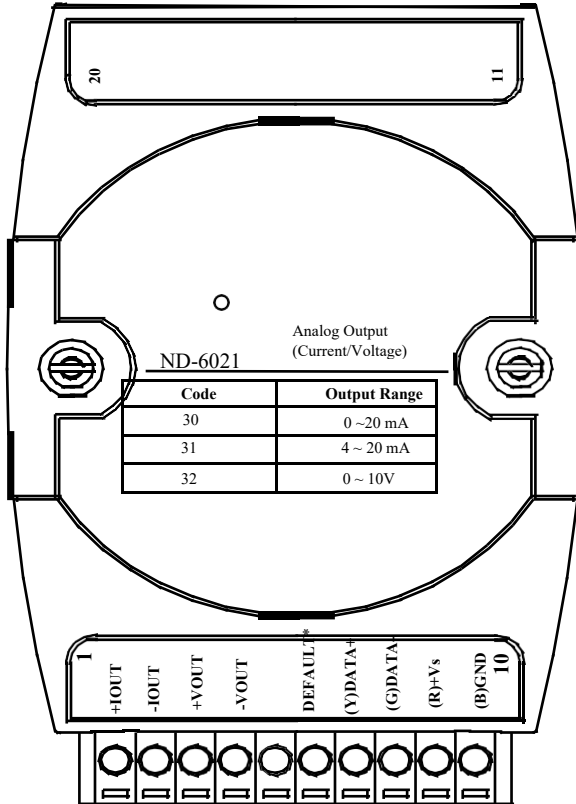

Functional Block Diagram of ND-6021

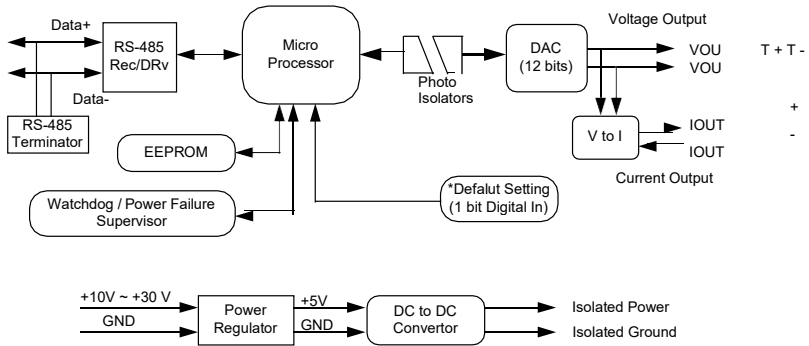

1.3 Overview of NuDAM-6024

What is NuDAM-6024

ND-6024 is a 4-channel bipolar analog signal output module. It receives the digital command from host computer through RS-485 network. A microprocessor is used to convert the digital command to digital value to send to DAC. The DAC converts the digital value into analog form.

The ND-6024 is designed for safety. It provides many safety functions such as isolation, watchdog, and power on safe value. The opto-isolators provide 5000Vrms isolation voltage to isolate the digital section and the remote-controlled analog equipment. The damage of power surges is avoided.

Another safety function is the watchdog. Whenever the host is loss contact with the remoted NuDAM module, or the micro-processor is down, the module will reset itself and send the safety value to the analog output therefore the industry safety is guarantee. The safety value / power-up value can be set by configuration software.

Features of NuDAM-6024

- 4 channel bipolar analog output
- Programmable host watchdog timer for host failure protection
- Internal watchdog timer for device failure protection
- Easy programming by software
- Easy installation and wiring

Specifications of NuDAM-6024

- ◆ **Interface**
 - Interface: RS-485, 2 wires
 - Speed (bps): 1200, 2400, 4800, 9600, 19.2K, 38.4K
- ◆ **Analog Output**
 - Channel numbers: 4
 - Signal Output type: Differential output

◆ **Voltage Output: $\pm 10V$**

- Resolution: 12-bit resolution
- Accuracy: $\pm 1/2$ LSB
- Gain Drift: $\pm 5\text{ppm}/^\circ\text{C}$

◆ **Digital Input**

- Channel numbers: 7
- Logical level 0: +2V max. Logical Level 1: +3.5V ~ +30V

◆ **Isolation**

- Isolation voltage: 5000 Vrms

◆ **Watchdog Function**

- Module internal watchdog timer: 150 ms
- Power failure threshold: 4.65 V
- Host programmable watchdog: 100 ms ~ 25.500 sec

◆ **Power**

- Power supply: +10V to +30V
- Power consumption: 2.5W

Pin Definitions of ND-6024

Pin #	Signal Name	Description
1	D14	Digital input channel 4
2	D13	Digital input channel 3
3	D12	Digital input channel 2
4	D11	Digital input channel 1
5	D10	Digital input channel 0
6	Default*	Initial state setting
7	(Y) DATA+	RS-485 series signal, positive
8	(G) DATA-	RS-485 series signal, negative
9	(R) +Vs	Power supply, +10V~+30V
10	(B) GND	Ground
11	VOUTA+	Positive Voltage Output A Terminal
12	AGND	Negative Voltage Output A Terminal
13	VOUTB+	Positive Voltage Output B Terminal
14	AGND	Negative Voltage Output B Terminal
15	VOUTC+	Positive Voltage Output C Terminal
16	AGND	Negative Voltage Output C Terminal
17	VOUTD+	Positive Voltage Output D Terminal
18	AGND	Negative Voltage Output D Terminal
19	D16	Digital input channel 6
20	D15	Digital input channel 5

A Look at ND-6024 & Pin Assignment

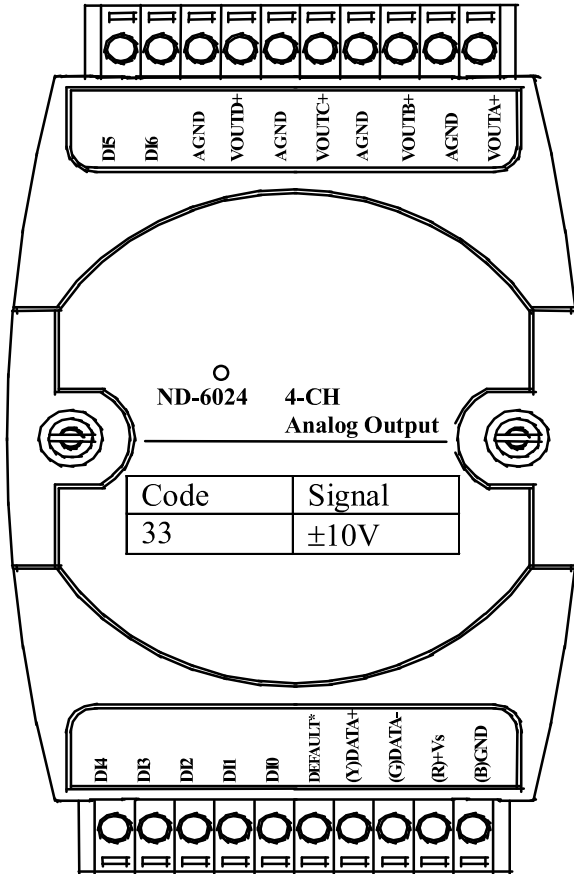

Functional Block Diagram of ND-6024

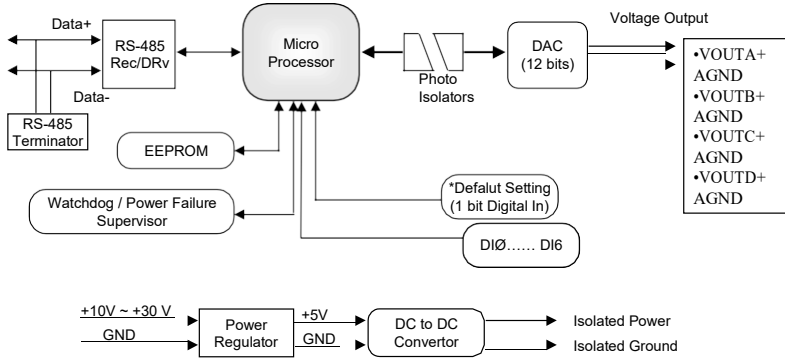

This page intentionally left blank.

2

Initialization & Installation

2.1 Software Installation

1. If you have already installed “NuDAM Administration” then skip other steps.
2. Backup your software diskette.
3. Insert “NuDAM Administration” diskette into floppy drive A:
4. Change drive to A:
5. Installation command syntax

INSTALL drive:

drive name is C to Z.

Example 1 : install to drive C:

A:\> **INSTALL C:**

Example 2 : install to drive F:

A:\> **INSTALL F:**

6. NuDAM Administration Utility will be installed in the directory C:\NUDAM

2.2 Initializing a Brand-New Module

Objective of Initializing a Brand-New NuDAM

All NuDAM modules, except NuDAM-6520 and NuDAM-6510, in a RS-485 network must have an *unique* address ID. Every brand-new NuDAM has a factory default setting as following:

- Address ID is 01
- Baud rate is 9600 bps
- Check-sum disable
- Host Watchdog timer is disable

Therefore, to configure the brand-new NuDAM before using is necessary to avoid conflicting address. The baud rate may also be changed according to user's requirements.

The initialization procedures of a brand-new NuDAM are shown in the following sections.

Default State

The NuDAM modules must be set at *Default State* when you want to change the default settings, including the ID address, baud rate, check-sum status etc. All NuDAM modules have an special pin labeled as **DEFAULT***. The module will be in *Default State* if the **DEFAULT*** pin is shorted to ground when power ON. Under this state, the default configuration is set as following:

- Address ID is 00
- Baud rate is 9600 bps
- Check-sum disable
- Watchdog timer is disable

Therefore, the configuration of the host and the module can be easily set identically and initializing a module will be possible no matter what configuration is set under operating state.

Initialization Equipment

- Host computer with an RS-232 port
- An installed RS-485 module (NuDAM-6520) with 9600 baud rate
- The brand new NuDAM module
- Power supply (+10 to +30 VDC) for NuDAM modules
- Administrating utility software

Initialization Procedure

1. Power off the host computer and the installed NuDAM-6520. Be sure of the baud rate of the NuDAM-6520 is 9600 bps.
2. Connect a brand new NuDAM module with the RS-485. Set the module in *Default State* by shorting the **DEFAULT*** pin. Refer to Figure 2.1 for detailed wiring.
3. Power on the host computer.
4. Power on the power supply for NuDAM modules.
5. Use the NuDAM Administrating utility to configure the address ID, Baud rate and check-sum status of the module.

Initialization Wiring

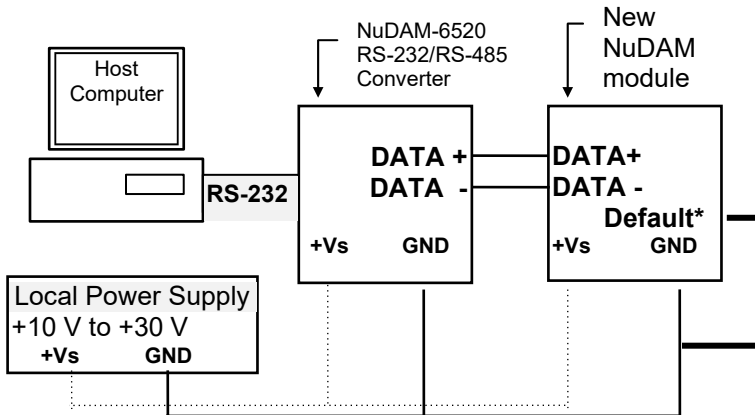

Figure 2-1 Layout for Initialization the NuDAM module

2.3 Install a New NuDAM to a Existing Network

Equipment to Install a New Module

- A existing NuDAM network
- New NuDAM modules
- Power supply (+10 to +30 V_{DC})

Installing Procedures

1. Configure the new NuDAM module according to the initialization procedure in section 2.2.
2. The baud rate and check-sum status of the new module must be identity with the existing RS-485 network. The address ID must not be conflict with other NuDAM modules on the network.
3. Power off the NuDAM power supply of the existing RS-485 network.
4. Power off the host computer.
5. Wire the power lines for the new NuDAM with the existing network. Be careful about the signal polarity as wiring.
6. Wire the RS-485 data lines for the new NuDAM with the existing network. Be careful about the signal polarity as wiring.
7. Wire to the input or output devices. Refer to section 2.4 for illustrations.
8. Power on the host computer.
9. Power on the NuDAM local power supply.
10. Use the NuDAM administration utility to check entire network.

2.4 Application Wiring for NuDAM-6021

Differential Current Output

Differential Current Output Channel of NuDAM 6021

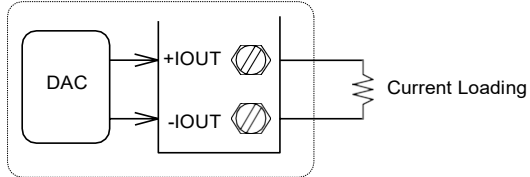

Differential Voltage Output

Differential Voltage Output Channel of NuDAM 6021

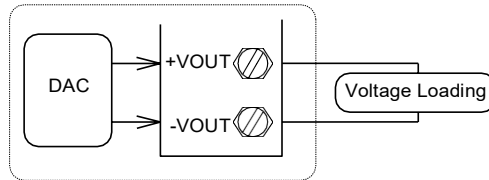

2.5 Application Wiring for NuDAM-6024

Differential Voltage Output

Differential Voltage Output Channel of NuDAM 6021

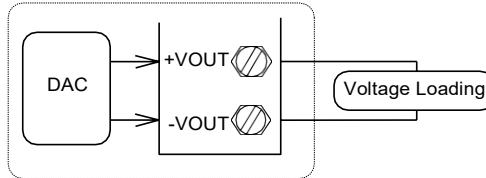

3

Command Set

3.1 Command and Response

Introduction

The NuDAM command is composed by numbers of characteristics, including the leading code, address ID, the variables, the optional check-sum bytes, and a carriage return to indicate the end of a command. The host computer can only command only one NuDAM module except those synchronized commands with wildcard address “***”. The NuDAM may or may not give response to the command. The host should check the response to handshake with the modules.

Document Conventions

The following syntax conventions describes the NuDAM commands in this manual.

(Leading Code)	Leading Code is the first characteristic of the NuDAM command. All NuDAM commands need a command leading code, such as %, \$, #, @, ...etc. 1- character
(Addr)	Module's address ID, the value is in the range of 00 - FF (Hex). 2- character
(Command Variable)	Command codes or value of variables. Variable length
[Data]	Some commands need additional data. Variable length
[Checksum]	Checksum in brackets indicate optional parameter, only checksum is enable then this field is required.

	2- character
< >	Identifies a control code character, such as <CR> for carriage return, its value is 0x0D. 1- character

Format of NuDAM Commands

(Leading Code)(Addr)(Command)[Data][Checksum]<CR>

When checksum is enable then [Checksum] is needed, it is 2-character. Both command and response must append the checksum characters.

How to calculate checksum value ?

[Checksum] = ((LeadingCode)+(Addr)+(Command)+[Data]) MOD 0x100

Example 1: checksum is disable

User Command : \$012<CR>
 Response : !01400600<CR>

\$: LeadingCode
 01 : Address
 2 : Command (Read Configuration)
 <CR> : Carriage return 0x0D

Example 2: checksum is enable

User Command : \$012**B7**<CR>
 Response : !01400600**AC**<CR>

\$: LeadingCode
 01 : Address
 2 : Command (Read Configuration)
 B7 : Checksum value
 <CR> : Carriage return 0x0D

'\$' = 0x24 '0' = 0x30 '1' = 0x31 '2' = 0x32

B7 = (0x24 + 0x30 + 0x31 + 0x32) MOD 0x100

'!' = 0x24 '0' = 0x30 '1' = 0x31

'4' = 0x34 '6' = 0x36

AC = (0x24 + 0x30 + 0x31 + 0x34 + 0x30 + 0x30 + 0x36 + 0x30)

MOD 0x100

-
- Note :** 1. There is no spacing between the command words and the checksum characters.
2. Every command follows a <CR> carriage return for ending.
3. The checksum characters are optional.
-

Response of NuDAM Commands

The response message depends on versatile NuDAM command. The response is composed with a few characteristics, including leading code, variables, and carriage return for ending. There are two categories of leading code for response message, "!" or ">" means valid command and "?" means invalid. By checking the response message, user can monitor the command is valid or not.

-
- Note :** Under the following conditions, there will have **no response** message.
1. The specified address ID is not exist.
 2. Syntax error.
 3. Communication error.
 4. Some special commands does not have response message .
-

3.2 Summary of Command Set

There are three categories of NuDAM commands. The first is the general commands, including set configuration command, read configuration, reset, read module's name or firmware version, etc. Every NuDAM can response to the general commands. The second is the functional commands, which depends on functions of each module. Not every module can execute all function commands. The third is the special commands including functions about the programmable watchdog timer, safe values, and the programmable leading code. All the commands used in the NuDAM analog output module are list in the following table.

Command Set of Analog Output Modules			
Command	Syntax	Module s	Page
General Commands			
Set Configuration	%(OldAddr)(NewAddr) (OutputRange)(BaudRate) (DataFormat)	All	23
Read Configuration	\$(Addr)2	All	26
Read Module Name	\$(Addr)M	All	27
Read Firmware Version	\$(Addr)F	All	28
Reset Status	\$(Addr)5	All	29
Functional Commands			
Synchronized Sampling	#**	6024	
Read Synchronized Data	\$(Addr)9	6024	
Digital Input	\$(Addr)8	6024	
Analog Data Out	#(Addr)(OutData)	6021	30
	#(Addr)(Port)(OutData)	6024	
4 mA Offset Calibration	\$(Addr)0	6021(1)	35
20 mA Offset Calibration	\$(Addr)1	6021(1)	36
Trim Calibration	\$(Addr)3(Counts)	All(1)	37
Save Power On Analog Value	\$(Addr)4	All	38
Last Value Readback	\$(Addr)6	6021	39
	\$(Addr)6(Port)	6024	
Current Readback	\$(Addr)8	6021	40
Special Commands			
Read Command Leading Code Setting	~(Addr)0	All	Error! Bookmark not defined.
Change Command	~(Addr)10(C1)(C2)(C3)	All	43

Leading Code Setting	(C4)(C5)(C6)		
Set Host Watchdog / Safety Value	~(Addr)2(Flag)(TimeOut) (SafeValue)	6021	45
	~(Addr)2(Flag)(TimeOut) (SafeA)(SafeB)(SafeC) (SafeD)	6024	
Read Host WatchDog / Safe Value	~(Addr)3	All	48
Host is OK	~**	All	50

Note: "ALL" means for ND-6021, ND-6024

(1) For Firmware Reversion E1.00, the command must be processed in
*Default mode.

3.3 Set Configuration

@Description

Configure the basic setting of NuDAM, including the address ID, output signal range, baud rate, and data format. The new configuration will be available after executing the command.

@Syntax

%(OldAddr)(NewAddr)(OutputRange)(BaudRate)(DataFormat)<CR>

%	Command leading code. (1-character)
(OldAddr)	NuDAM module original address ID. The default address ID of a brand new module is 01 . The value range of address ID is 00 to FF in hexadecimal. (2-character)
(NewAddr)	New address ID, if you don't want to change address ID, let new address ID equals to the old one. (2-character)
(OutputRange)	Define analog output range, refers to Table 3-1 for details. (2-character)
(BaudRate)	Define communication baud rate, refers to Table 3-2 for details. (2-character)
(DataFormat)	Define checksum, integration time and output data format, refers to Figure 3-1 for details. (2-character)

@Response

!(Addr)<CR>

or

?(Addr)<CR>

(Addr)	Address ID.
!	Command is valid.
?	Command is invalid, parameter values are invalid, or change the setting without grounding the DEFAULT* pin.

Note : When you want to change the checksum or baud rate, the DEFAULT* pin must be grounded at first.

@Example

User command: %0118310610<CR>
 Response: !18<CR>

Item	Meaning	Description
%	(Leading Code)	Command leading code.
01	(OldAddr)	Original address ID is 01(Hex).
18	(NewAddr)	New address ID is 18(Hex).
31	(OutputRange)	Analog output range is 4 to 20 mA
06	(BaudRate)	Baud rate is 9600.
10	(DataFormat)	10 means a slew rate is 1.000 mA/sec and checksum is disable.
<CR>	Carriage return	0x0D.

Code (Hex)	Signal Range of Output Range	Modules
30	0 to 20 mA	6021
31	4 to 20 mA	6021
32	0 to 10 V	6021
33	-10 to 10 V	6024

Table 0-1 Analog Output Range Setting

Code	Baudrate
03	1200 bps
04	2400 bps
05	4800 bps
06	9600 bps
07	19200 bps
08	38400 bps

Table 3-2 Baud rate setting code

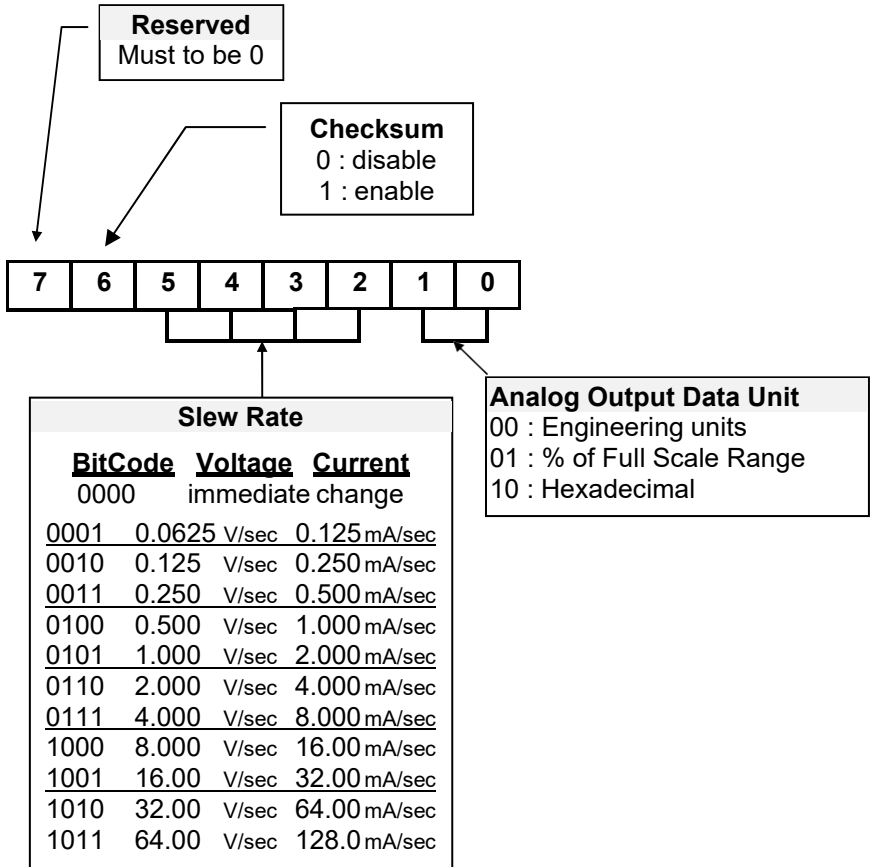

Figure 3-1 Data format of Analog Output Setting

**6024 only supports immediate change and engineering units.*

3.4 Read Configuration

@Description

Read the configuration of module on a specified address ID.

@Syntax

`$(Addr)2<CR>`

\$	Command leading code
(Addr)	Address ID.
2	Command code for reading configuration

@Response

`!(Addr)(OutputRange)(BaudRate)(DataFormat)CR>`

or

`?(Addr)<CR>`

!	Command is valid.
?	Command is invalid.
(Addr)	Address ID.
(OutputRange)	Current setting of analog voltage output, refer to Table 3-1 for details.
(BaudRate)	Current setting of communication baud rate, refer to Table 3-2 for details.
(DataFormat)	Current settings of checksum, integration time and output data format, refers to Figure 3-1 for details.

@Example

User command:	<code>\$182<CR></code>
Response:	<code>!18320610<CR></code>

!	Command is valid.
18	Address ID.
32	Analog output range is 0 to 10V
06	Baud rate is 9600 bps.
10	The output data is in engineering units, slew rate is 1mA/sec, checksum is disable.

3.5 Read Module Name

@Description

Read module name of NuDAM at specified address.

@Syntax

\$(Addr)M<CR>

\$	Command leading code.
(Addr)	Address ID.
M	Read module name.

@Response

!(Addr)(ModuleName) <CR>

or

?(Addr)<CR>

!	Command is valid.
?	Command is invalid.
(Addr)	Address ID.
(ModuleName)	NuDAM module's name would be '6021'. 4 characters

@Example

User command:	\$18M<CR>
Response:	!186021<CR>

!	Command is valid.
18	Address ID is 18 (Hex).
6021	ND-6021 (It is a analog output module)

3.6 Read Firmware Version

@Description

Read firmware version of NuDAM at specified address.

@Syntax

`$(Addr)F<CR>`

- \$** Command leading code.
- (Addr)** Address ID
- F** Read module firmware version.

@Response

`!(Addr)(FirmRev) <CR>`

or

`?(Addr)<CR>`

- !** Command is valid.
- ?** Command is invalid.
- (Addr)** Address ID.
- (FirmRev)** NuDAM module's firmware version.

@Example

User command:	<code>\$18F<CR></code>
Response:	<code>!18A2.30<CR></code>

- !** Command is valid.
- 18** Address ID is 18 (Hex).
- A2.30** Firmware Version

3.7 Reset Status

@Description

Read the reset status of module at specified address to check whether if it has been reset since the last reset status command was issued to the module.

@Syntax

\$(Addr)5<CR>

\$	Command leading code.
(Addr)	Address ID.
5	Reset Status Command.

@Response

!(Addr)(Status)<CR>

or

?(Addr)<CR>

!	Command is valid.
?	Command is invalid.
(Addr)	Address ID.
(Status)	0 : It has not been reset since the last reset status command was issued.
	1 : It has been reset since the last reset status command was issued.

@Example

User command:	\$185<CR>
Response:	!180<CR>

Status is 0 means this digital I/O module has not been reset, since the last reset status command was issued.

3.8 Synchronized Sampling (6024 only)

@Description

Synchronized all modules to sample input values and stored the values in the module's register at the same time and use "Read Synchronized Data" command to read the data and process it one by one.

For analog output module, this command is only available to modules involving the digital input function, such as NuDAM-6024.

@Syntax

```
##* <CR>
```

#	Command leading code.
**	Synchronized sampling command

@Response

Note : Synchronized sampling command **has NO response**.

@Example

```
User command: ##* <CR>
```

Synchronized sampling command **has no response**.

3.9 Read Synchronized Data (6024 only)

@Description

After a synchronized sampling command **##*** was issued, you can read the input value that was stored in the addressed module's register and use same method to process other module's data one by one.

@Syntax

\$(Addr)9<CR>

\$	Command leading code.
(Addr)	Address ID.
9	Read synchronized data.

@Response

!(Status)(DataIn)<CR>

or

?(Addr)<CR>

>	Command is valid.
?	Command is invalid.
	0 : Data has been sent at least once before.
(Status)	1 : Data has been sent for the first time since a synchronized sampling command was issued. (1-character)
(DataIn)	Value of digital input channel. (2-character) .

@Examples

User command:	\$309<CR>
Response:	>17F<CR>

>	Command is valid.
1	Data has not been sent before.
7F	7F(01111111) means digital inputchannel 0,1,2,3,4,5,6 are HIGH.

3.10 Digital Input (6024 only)

@Description

Read the digital input channel value.

@Syntax

\$(Addr)8<CR>

\$	Command leading code.
(Addr)	Address ID
8	Digital data input command.

@Response

!(DataIn)0000<CR>

or

?(Addr)<CR>

!	Command is valid.
?	Command is invalid.
(DataIn)	Value of digital input. (2-character)

@Example

User command:	\$308<CR>
Response:	!320000<CR>

!	Command is valid.
32	32 (00110010) means digital output channel 1, 4, 5 are ON, channel 0, 2, 3, 6 are OFF.
0000	No used

3.11 Analog Data Output

@Description

Send a value to analog output module at specified address. The data format of the value can be engineering unit, percent, or hexadecimal value, which is set by configuration setting command.

(ND-6024 only supports engineering format.)

@Syntax

#(Addr)(OutData)<CR> (6021 Only)

#(Addr)(Port)(OutData)<CR> (6024 Only)

#	Command leading code. (1-character)
(Addr)	Address ID. (2-character)
(Port)	A, B, C or D
(OutData)	Value of the analog output signal,. The unit of the value can be engineering units, % of FSR, or hexadecimal value. Refers to chapter 4 for details of the data format.

@Response

<CR>

or

?(Addr)<CR>

>	Command is valid.
?	Command is invalid or no synchronized sampling command was issued.
(Addr)	Address ID.

@Examples

User command:	#0616.000<CR>
Response:	><CR>

The command sets the analog output to be 16 mA at address 06H, if the data format is configured as engineering units and 0~20mA output range.

User command:	#08+020.00<CR>
Response:	><CR>

The command sets the analog output to be 4 mA at address 08H, if the data format is configured as % of FSR and 0~20mA output range.

$$4\text{mA} = 20\text{mA} \times 20.00\%$$

```
User command: #097FF<CR>
Response: ><CR>
```

The command sets the analog output to be 5 V at address 09H, if the data format is configured as hexadecimal format and output range of 0~10V.

$$5\text{ V} = 7\text{FF} / \text{FFF} \times 10\text{V}$$

```
User command: #08A-05.000<CR>
Response: ><CR>
```

The command sets the analog output port A to be -5 V at address 08H.

3.12 4mA Offset Calibration

@Description

Stores the current output value as 4 mA reference at the specified analog output module.(only 6021)

@Syntax

\$(Addr)0<CR>

\$	Command leading code
(Addr)	Address ID
0	Command Code

@Response

!(Addr)<CR>

or

?(Addr)<CR>

!	Command is valid.
?	Command is invalid or no synchronized sampling command was issued.
(Addr)	Address ID.

@Example

User command:	\$060<CR>
Response:	!06<CR>

To perform the 4 mA calibration for analog output module at address 06H.

Note : Analog output module should be trimmed to the correct value by “Trim Calibration” command before to execute “4 mA Calibration”. Refers to Chapter 5 “Analog Output Calibration” for details.

3.13 20mA Calibration

@Description

Stores the current output value as 20 mA reference at the specified analog output module. (only 6021)

@Syntax

\$(Addr)1<CR>

\$	Command leading code (1 character)
(Addr)	Address ID (2 characters)
1	Function Code, 20 mA calibration (1 character)

@Response

!(Addr)<CR>

or

?(Addr)<CR>

!	Command is valid.
?	Command is invalid.
(Addr)	Address ID.

@Example

User command:	\$061<CR>
Response:	!06<CR>

To perform the 20 mA calibration for analog input module at address ID 06H.

Note : Analog output module should be trimmed to the correct value by "Trim Calibration" command before to execute "20 mA Calibration". Refers to Chapter 5 "Analog Output Calibration" for details .

3.14 Trim Calibration

@Description

Trims the specified analog output module a specified number of units up or down.

@Syntax

\$(Addr)3(Counts)<CR>

\$	Command leading code
(Addr)	Address ID
3	Function Code
	Number of counts to increase or decrease the output current.
(Counts)	Range 00 - 5F : 0 to +95 counts (increase) Range A1 - FF : -95 to -1 counts (decrease) 1 count equals approximately 4.88 μ A or 2.44mV (4.88mV for ND-6024)

@Response

!(Addr)<CR>

or

?(Addr)<CR>

!	Command is valid.
?	Command is invalid.
(Addr)	Address ID.

@Example

```
User command: $06314<CR>
Response: !06<CR>
```

Increase analog output value about 97.6 μ A (14H * 4.88 μ A = 97.6 μ A) at address 06H.

Note : Analog output module trim calibration should have a correct calibration wiring. Refers to Chapter 5 “Analog Output Calibration” for details.

3.15 Save Power On Analog Output Value

@Description

Save the current output value to the non-volatile register for NuDAM analog output module. The power on value be put on the output channel when system power ON.

@Syntax

```
$(Addr)4<CR>
```

\$	Command leading code. (1-character)
(Addr)	Address ID. (2-character)
4	Function code of saving power on analog value. (1-character)

@Response

```
!(Addr)<CR>
```

or

```
?(Addr)<CR>
```

!	Command is valid.
?	Command is invalid.
(Addr)	Address ID.

@Example

```
User command: $064<CR>
Response: !06<CR>
```

Save the current analog output value as the default value when the analog output module start-up.

3.16 Last Value Readback

@Description

Return the latest analog output value which is set by “Analog Data Out” command. If the analog output module never execute the “Analog Data Out” command then it return the start-up output value. (only 6021)

@Syntax

\$(Addr)6<CR>

\$(Addr)6(Port)<CR> (6024 Only)

\$	Command leading code. (1-character)
(Addr)	Address ID. (2-character)
6	Function code of last value readback. (1-character)
(Port)	Port A, B, C or D.

@Response

!(Addr)(Data)<CR>

or

?(Addr)<CR>

!	Command is valid.
?	Command is invalid.
(Addr)	Address ID.
(Data)	The current analog output value, the data format depends on module configuration.

@Example

```
User command:  $086<CR>
Response:      !0802.000<CR>
```

This analog output module returns the latest output value is 2.000 mA at address 08H, if data format is engineering units and the signal range is 0~20mA.

3.17 Current Readback

@Description

Read the estimated current output value at the specified analog output module.

@Syntax

`$(Addr)8<CR>`

\$	Command leading code. (1-character)
(Addr)	Address ID. (2-character)
6	Function code of last value readback. (1-character)

@Response

`!(Addr)(Data)<CR>`

or

`?(Addr)<CR>`

!	Command is valid.
?	Command is invalid.
(Addr)	Address ID.
(Data)	The current analog output value, the data format depends on module configuration.

@Example

User command:	\$088<CR>
Response:	!0802.000<CR>

This analog output module returns the latest output value is 2.000 mA at address 08H, if data format is engineering units and the signal range is 0~20mA.

3.18 Read

@Description

Read command leading code setting and host watchdog status.

@Syntax

~(Addr)0<CR>

~	Command leading code.
(Addr)	Address ID
0	Read command leading code setting.

@Response

!(Addr)(Status)(C1)(C2)(C3)(C4)(C5)(C6)<CR>

or

?(Addr)<CR>

!	Command is valid.
?	Command is invalid.
(Addr)	Address ID. (2-character)
(Status)	Bit 0 : Reserved Bit 1 : Power failure or watchdog failure Bit 2 : Host watchdog is enabled Bit 3 : Host failure
(C1)	Leading code 1, for read configuration status, firmware version, etc. default is \$. (1-character)
(C2)	Leading code 2, for read synchronize sampling, digital output ,default is #. (1-character)
(C3)	Leading code 3, for change configuration. default is %. (1-character)
(C4)	Leading code 4, for read alarm status, enable alarm, etc. default is @. (1-character)
(C5)	Leading code 5, for read command leading code, change command leading code, etc. default is ~. (1-character)
(C6)	Leading code 6, this leading code is reserved. default is *. (1-character)

@Example

```
User command: ~060<CR>  
Response: !0600$#%@~* <CR>
```

Command leading code setting is \$#%@~* for module address ID is 06, current status is factory default setting.

3.19 Change Leading Code Setting

@Description

User can use this command to change command leading code setting as he desired.

@Syntax

~(Addr)10(C1)(C2)(C3)(C4)(C5)(C6)<CR>

- ~ Command leading code.
- | | |
|---------------|--|
| (Addr) | Address ID, range (00 - FF). |
| 10 | Change command leading code setting. |
| (C1) | Leading code 1, for read configuration status, firmware version, etc. default is \$.
(1-character) |
| (C2) | Leading code 2, for read synchronize sampling, digital output, default is # . (1-character) |
| (C3) | Leading code 3, for change configuration. default is % . (1-character) |
| (C4) | Leading code 4, for read alarm status, enable alarm, etc. default is @ . (1-character) |
| (C5) | Leading code 5, for read command leading code, change leading code, etc. default is ~ .
(1-character) |
| (C6) | Leading code 6, this leading code is reserved. default is * . (1-character) |

@Response

!(Addr)< CR>

or

?(Addr)<CR>

!	Command is valid.
?	Command is invalid.
(Addr)	Address ID.

@Examples

```

User command: ~060<CR>
Response: !0600$#%@~*<CR>
User command: ~0610A#%@~*<CR>
Response: !06<CR>
User command: A06F
Response: !06A1.8<CR>

```

Read leading code setting is \$#%@~* for module address 06 and change leading code \$ to A, then use A06F to read firmware version of module on address 06.

***** WARNING *****

- We do not recommend users to change the default setting of leading code, because it will confuse yourself.
- The leading code change only use the command conflicts other devices of other brand on the network.
- The changing of leading code is not necessary if all modules in a network are NuDAMs'.

3.20 Set Host Watchdog Timer & Safety Value

@Description

Set host watchdog timer, module will change to safety state when host is failure. Define the output value in this command.

@Syntax

~(Addr)2(Flag)(TimeOut)(SafeValue)<CR>

~(Addr)2(Flag)(TimeOut)(SafeA)(SafeB)(SafeC)(SafeD) (6024 Only)

~	Command leading code.
(Addr)	Address ID, range (00 - FF).
2	Set host watchdog timer and safe state value.
(Flag)	0 : Disable host watchdog timer 1 : Enable host watchdog timer (1-character)
(TimeOut)	Host timeout value, between this time period host must send (Host is OK) command to module, otherwise module will change to safety state. Range 01 - FF. (2-character) One unit is 53.3 ms (Firmware version 1.x) 01 = 1 * 53.3 = 53.3 ms FF = 255 * 53.3 = 13.6 sec One unit is 100 ms (Firmware version 2.x) 01 = 1 * 100 = 100 ms FF = 255 * 100 = 25.5 sec
(SafeValue)	Safety value of analog output when host is failure. (3-character) 000: analog output is 0mA or 0 V 7FF: analog output is 10 mA or 5V FFF: analog output is 20 mA or 10V
(SafeA)	Safety value of analog output for port A, B, C and D when host is failure. (3-character)
(SafeB)	
(SafeC)	
(SafeD)	

@Response

!(Addr)<CR>

or

?(Addr)<CR>

!	Command is valid.
?	Command is invalid.
(Addr)	Address ID

@Example

User command:	~0621123F0<CR>
Response:	!06<CR>

06	Address ID
2	Set host watchdog timer and safe state value.
1	Enable host watchdog timer.
	Timeout value. $0x12 = 18$
12	$18 * 53.3 = 959 \text{ ms}$ (Firmware Version 1.x)
	$18 * 100 = 1800 \text{ ms}$ (Firmware Version 2.x)
	0x3F0 is hexadecimal
3F	Analog output value is 4.923 mA for 0-20mA
0	Analog output value is 4.923 mA for 4-20mA
	Analog output value is 2.462 V for 0-10 V

Analog output safety value are as following :

For type is 0 ~20 mA or 4~20 mA (Output Range is 0x30, 0x31)

$$\text{value} = (0x3F0 / 0xFFFF) * 20 \text{ mA} = 4.923 \text{ mA}$$

For type is 0 ~10V (Output Range is 0x32)

$$\text{value} = (0x3F0 / 0xFFFF) * 10 \text{ V} = 2.462 \text{ V}$$

```
User command: ~062112800800800800<CR>
Response: !06<CR>
```

06	Address ID
2	Set host watchdog timer and safe state value.
1	Enable host watchdog timer. Timeout value. 0x12 = 18
12	18 * 53.3 = 959 ms (Firmware Version 1.x) 18 * 100 = 1800 ms (Firmware Version 2.x)
800	0x800 is hexadecimal
800	Analog output value is 0V for port A
800	Analog output value is 0V for port B
800	Analog output value is 0V for port C
800	Analog output value is 0V for port D

3.21 Read Host Watchdog Timer & Safety Value

@Description

Read host watchdog timer setting and the safety value.

@Syntax

~(Addr)3<CR>

~	Command leading code.
(Addr)	Address ID
3	Read host watchdog setting and module safety state value.

@Response

!(Addr)(Flag)(TimeOut)(SafeValue)<CR>

!(Addr)(Flag)(TimeOut)(SafeA)(SafeB)(SafeC)(SafeD)<CR>(6024Only)

or

?(Addr)<CR>

!	Command is valid.
?	Command is invalid.
(Addr)	Address ID, range (00 - FF).
(Flag)	0 : Host watchdog timer is disable 1 : Host watchdog timer is enable(1-character)
(TimeOut)	Host timeout value. Range 01 - FF. (2-character) One unit is 53.3 ms (Firmware version 1.x) 01 = 1 * 53.3 = 53.3 ms FF = 255 * 53.3 = 13.6 sec One unit is 100 ms (Firmware version 2.x) 01 = 1 * 100 = 100 ms FF = 255 * 100 = 25.5 sec
(SafeValue)	Safety value of analog output when host is failure. (3-character)
(SafeA)	Safety value of analog output for port A, B, C and D when host is failure. (3-character)
(SafeB)	
(SafeC)	

@Example

```
User command: ~063<CR>
Response: !061123F0<CR>
```

```
06      Address ID
1       Host watchdog timer is
        enable. Timeout value.
        0x12 = 18
12      18 * 53.3 = 959 ms (Firmware Version 1.x)
        18 * 100 = 1800 ms (Firmware Version 2.x)
        0x3F0 is hexadecimal
3F0     Analog output value is 4.923 mA for 0-20mA
        Analog output value is 4.923 mA for 4-20mA
        Analog output value is 2.462 V for 0-10 V
```

```
User command: ~063<CR>
Response: !06112800800800800<CR>
```

```
06      Address ID
1       Host watchdog timer is enable.
        Timeout value. 0x12 = 18
12      18 * 53.3 = 959 ms (Firmware Version 1.x)
        18 * 100 = 1800 ms (Firmware Version 2.x)
        0x800 is hexadecimal
800     Analog output value is 0V for port A
800     Analog output value is 0V for port B
800     Analog output value is 0V for port C
800     Analog output value is 0V for port D
```

3.22 Host is OK

@Description

When host watchdog timer is enable, host computer must send this command to every module before timeout otherwise “**host watchdog timer enable**” module’s output value will go to safety state output value.

Timeout value and safety state output value is defined in 3.14. “Set Host Watchdog Timer & Safety Value”

@Syntax

```
~**<CR>
```

~

Command leading code.

**

Host is OK.

@Response

Note : Host is OK command **has NO response.**

@Example

```
command: ~**<CR>
```

4

Data Format

4.1 Unit Conversion

The data value in the command of the analog output module is corresponding to the amplitude of the physical analog signal. The user should understand the data format to represent a analog signal by an ASCII string. The physical meaning of a data depends on both the unit conversion and the value. The unit conversion of the digits value can be configured by the setting configuration command. Three types of unit conversion are used in analog output modules.

1. Engineering units.
2. Percent of FSR (Full Scale Range).
3. Hexadecimal.

4.2 Engineering Units

The data is in engineering unit when the bit 1 and 0 of the configuration register are '00'. The data string is composed by **6** characters. Because the output of ND-6021 is unipolar, the value is always positive.

The meaning of the value depends on the output range setting too. When the output range is set to 0~10V, the unit of the value is in 'Volts'. When the output range is set to 0~20mA or 4~20mA, the unit of the value is in 'mA'.

- Set bit 1 and bit 0 of data format variable to "00" means the data is represented in engineering units
- Data string is fixed length of 6 characters. The value is composed of five decimal digits with a decimal fixed point
- Two digits present the integer part and three present the fraction

Example 4.2.1:

- If the output range is set as 0 to 20 mA
- The desired analog output value is +5.678

mA The data value should be : **05.678<CR>**

Example 4.2.2:

- If the output range is set as 0 to 10 V
- The desired analog output value is +2.345 V

The data value should be : **02.345<CR>**

4.3 Percent of FSR

The data is in percent of FSR(Full Scale Range) when the bit 1 and 0 of the configuration register are '01'. The data string is composed by **6** characters. Because the output of ND-6021 is unipolar, the value is always positive.

The value is unit-less and depends on the output range setting too.

- Set bit 1 and bit 0 of data format variable to "01" means the data is represented in percent of FSR.
- Data string is fixed length of 6 characters. The value is composed of five decimal digits with a decimal fixed point.
- Three digits present the integer part and two digits present the fraction
- Maximum resolution is 0.2%.

Example 4.3.1 :

- If the output range is set as 0 to 20 mA
- The desired analog output current is 10 mA

The data value should be : **050.00<CR>**

$$10 \text{ mA} / 20 \text{ mA} = 50.00 \%$$

Example 4.3.2 :

- If the output range is set as 4 to 20 mA
- The desired analog output current is 10 mA

The data value should be : **037.50<CR>**

$$(10 \text{ mA} - 4 \text{ mA}) / (20 \text{ mA} - 4 \text{ mA}) = 37.50 \%$$

4.4 Hexadecimal Format

The data is in hexadecimal format as the bit 1 and 0 are set as '10'. The data string length is **3** characters. It is equivalent to 12 binary bits. Because the output of ND-6021 is unipolar, the maximum value of the digits is FFF(H) and the minimum value of the digits is 000(H).

As the output range is set to 0~20mA, the value 'FFF(H)' represents 20mA and '000(H)' represents 0mA. Similarly, as the output range is set to 4~20mA, the value 'FFF(H)' represents 20mA and '000(H)' represents 4mA.

Example 4.3.1 :

- If the output range is set as 0 to 20 mA
- The desired analog output current is 10 mA

Two's complement hexadecimal: **7FF<CR>**

4.5 Summary of Data Format

The following table shows the relation between the output range setting with the data format and the resolution.

Code	Output Range	Data Format	Maximum Value	Minimum Value	Output Resolution
30	0 to 20 mA	Eng. Units	20.000	00.000	4.88 μ A
31	4 to 20 mA	Eng. Units	20.000	04.000	4.88 μ A
32	0 to 10 V	Eng. Units	10.000	00.000	2.442 mV

Code	Output Range	Data Format	Maximum Value	Minimum Value	Output Resolution
30	0 to 20 mA	% of FSR	100.00	000.00	4.88 μ A
31	4 to 20 mA	% of FSR	100.00	000.00	4.88 μ A
32	0 to 10 V	% of FSR	100.00	000.00	2.442 mV

Code	Output Range	Data Format	Maximum Value	Minimum Value	Output Resolution
30	0 to 20 mA	Hexdecimal	FFF	000	4.88 μ A
31	4 to 20 mA	Hexdecimal	FFF	000	4.88 μ A
32	0 to 10 V	Hexdecimal	FFF	000	2.442 mV

This page intentionally left blank.

5

Analog Output Calibration

5.1 Calibration

The NuDAM analog output module needs to be calibrated. It has a factory default calibration . User can use NuDAM Administration utility to do any type of calibration.

5.2 Analog Output Module Calibration

What do you need to do calibration ?

1. One 5 1/2 digit multimeter.
2. A resistor 250 Ω (Accuracy is 0.01 %).
3. NuDAM Administration Utility.

Calibration Procedure

1. Select output range to 0 ~20 mA or 4~20 mA.
2. Put the resistor 250 Ω to the NuDAM-6021 (+ IOUT (Pin.1) and -IOUT (Pin.2)).
3. Put 5 1/2 digit multimeter to measure + IOUT (Pin.1) and -IOUT (Pin.2)

4. Send the “**Analog Data Output #**(Addr)(OutData)” command with output value is **4 mA**. For example if the address is 0x03 then the command is **#0304.000**.
5. Use “**Trim calibration \$(Addr)3(Counts)**” command to adjust until the output value to **1 V (4 mA)**.
6. Send “**4mA Calibration \$(Addr)0**” command to the analog output module to complete the 4 mA calibration.
7. Send the “**Analog Data Output #**(Addr)(OutData)” command with output value is **20 mA**. For example if the address is 0x03 then the command is **#0320.000**
8. Use “**Trim calibration \$(Addr)3(Counts)**” command to adjust until the output value to **5 V (20 mA)**.
9. Send “**20mA Calibration \$(Addr)1**” command to the analog output module to complete the 20 mA calibration.

Calibration wiring of NuDAM-6021

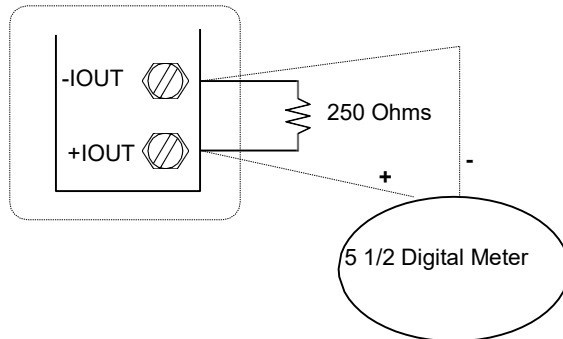

Safety Instructions

Read and follow all instructions marked on the product and in the documentation before you operate your system. Retain all safety and operating instructions for future use.

- Please read these safety instructions carefully.
- Please keep this User's Manual for later reference.
- Read the specifications section of this manual for detailed information on the operating environment of this equipment.
- When installing/mounting or uninstalling/removing equipment, turn off the power and unplug any power cords/cables.
- To avoid electrical shock and/or damage to equipment:
 - Keep equipment away from water or liquid sources.
 - Keep equipment away from high heat or high humidity.
 - Keep equipment properly ventilated (do not block or cover ventilation openings).
 - Make sure to use recommended voltage and power source settings.
 - Always install and operate equipment near an easily accessible electrical socket-outlet.
 - Secure the power cord (do not place any object on/over the power cord).
 - Only install/attach and operate equipment on stable surfaces and/or recommended mountings.
 - If the equipment will not be used for long periods of time, turn off and unplug the equipment from its power source.
- Never attempt to fix the equipment. Equipment should only be serviced by qualified personnel.

Getting Service

Ask an Expert: <http://askanexpert.adlinktech.com>

ADLINK Technology, Inc.

Address: No. 66, Huaya 1st Rd., Guishan District,
Taoyuan City 333411, Taiwan
Tel: +886-3-216-5088
Fax: +886-3-328-5706
Email: service@adlinktech.com

Ampro ADLINK Technology, Inc.

Address: 6450 Via Del Oro
San Jose, CA 95119-1208, USA
Tel: +1-408-360-0200
Toll Free: +1-800-966-5200 (USA only)
Fax: +1-408-600-1189
Email: info@adlinktech.com

ADLINK Technology (China) Co., Ltd.

Address: 300 Fang Chun Rd., Zhangjiang Hi-Tech Park, Pudong New Area
Shanghai, 201203 China
Tel: +86-21-5132-8988
Fax: +86-21-5132-3588
Email: market@adlinktech.com

ADLINK Technology GmbH

Address: Hans-Thoma-Straße 11
D-68163 Mannheim, Germany
Tel: +49-621-43214-0
Fax: +49-621 43214-30
Email: germany@adlinktech.com

Please visit the Contact page at www.adlinktech.com for information on how to contact the ADLINK regional office nearest you.